



ULTRA XT™

Introducing Graco's NEW Xtreme Torque™
Lineup of Professional Electric Airless Sprayers



PROVEN QUALITY. LEADING TECHNOLOGY.

**MADE IN THE USA WITH
GLOBAL COMPONENTS**

INTRODUCING
**BREAKTHROUGH
 XT TECHNOLOGY**
 PATENT PENDING

NEW FOR 2024



Ultra 490 XT Stand

**UP TO 10X QUIETER WITH THE
 NEW SOUND OF QUALITY™**

**UNRIVALED FINISH QUALITY WITH
 THE WORLD'S STEADIEST RUNNING
 PRESSURE**

SELECTABLE PERFORMANCE MODES™

LONGEST LIFE BEFORE SERVICE

FASTEST SERVICE ON JOBSITE

PUMP WEAR PREVENTION

**FASTEST CLEANING
 USING LESS FLUID**

LOWEST COST OF OWNERSHIP

**EXPERIENCE AIRLESS
 LIKE NEVER BEFORE**

XTREME TORQUE MOTOR

Experience a new level of performance with the first motor ever designed specifically for airless spray and made by Graco.

THE SOUND OF QUALITY

Advanced design eliminates multistage gear trains and reduces motor speed by 90% and noise by up to 10X.

RAPID-RESPONSE™ CONTROL

Delivers the world's steadiest running pressure. Dial-in 10 psi increments with the widest performance range in the industry (50-3,300 psi).

**SELECTABLE PERFORMANCE
 WITH THE PUSH OF A BUTTON**

Low Pressure Mode: Optimized performance range to eliminate overspray and improve finish.

High Pressure Mode: Offers maximum performance for extended hose lengths and difficult to atomise materials.

**ENDURANCE VORTEX® PISTON
 PUMPS WITH PROCONNECT®**

Auto-rotating vortex rod balances load and prolongs pump life—proven ProConnect replacement system eliminates downtime.

LED DIGITAL DISPLAY

Features a bright, easy-to-read LED display. See the performance from across the room!

TURBOCLEAN™

Efficiently cleans 3X faster using half the fluid, significantly reducing recycling costs.

WATCHDOG™ PUMP PROTECTION

Intelligent auto-shutoff feature activates when the sprayer runs out of paint, safeguarding the pump and maintaining consistent performance.



BREAKTHROUGH FEATURES ACROSS THE ENTIRE XT LINEUP

NEW FOR 2024

FEATURING
**BREAKTHROUGH
XTREME TORQUE MOTOR** PATENT PENDING

**1ST MOTOR EVER DESIGNED BY GRACO
SPECIFICALLY FOR AIRLESS SPRAY**

15X MORE TORQUE THAN TRADITIONAL MOTORS

8X MORE MAGNETS
DELIVERS RAPID ACCELERATION AND SMOOTH PERFORMANCE

90% LOWER RUNNING SPEEDS

**MONITORS PRESSURE 60X
PER MOTOR REVOLUTION**

**UP TO 10X QUIETER OPERATION DELIVERS
THE NEW SOUND OF QUALITY™**

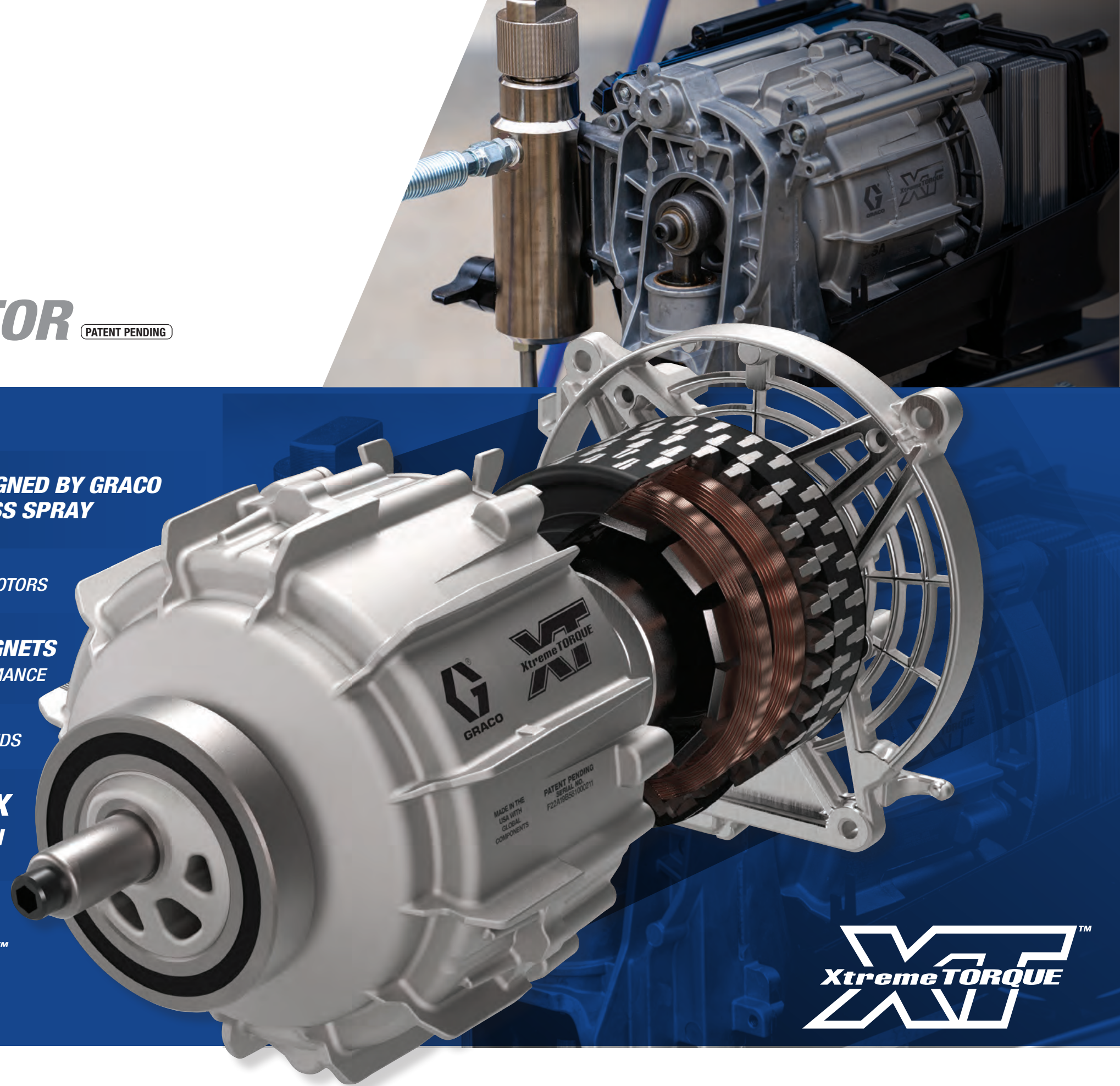

D E S I G N E D , E N G I N E E R E D & M A N U F A C T U R E D B Y G R A C O

FEATURING

THE WORLD'S WIDEST & STEADIEST RUNNING PRESSURE PATENT PENDING

EXPERIENCE NEXT-GENERATION PERFORMANCE

SPRAY MORE JOBS WITH THE WORLD'S STEADIEST PRESSURE CONTROL

- Rapid-Response™ Control eliminates pressure fluctuations by continuously monitoring pressure — 60X per motor revolution
- Instantly adjusts motor speed to eliminate 75% of pressure fluctuations for a Perfect Airless Finish™

WIDEST PERFORMANCE RANGE — FROM 50 TO 3,300 PSI

- Offers the largest operating pressure range providing full control and maximum productivity
- Flexible for more applications — coatings, hose lengths and tip sizes to meet every application

PUSH-BUTTON PERFORMANCE

- Two selectable performance modes offer unique performance levels to boost efficiency on every job
- Features a bright easy-to-read LED Display — see performance from across the room

MAXIMIZE UPTIME

- TurboClean™ cleans the pump 3X faster with 1/2 the fluid
- WatchDog™ Pump Protection automatically shuts down the sprayer when out of paint, preventing premature wear

BRING ON SAVINGS WITH SELECTABLE PERFORMANCE

LOW PRESSURE PERFORMANCE MODE

50 - 2,000 PSI

- Maximises savings, ideal for most projects with superior finish
- Optimised performance range to eliminate overspray and improve finish with RAC X™ LP SwitchTips™
- Adjustable in 10 psi increments — achieve extreme control down to 50 psi

HIGH PRESSURE PERFORMANCE MODE

500 - 3,300 PSI

- Ideal for difficult to atomise materials, extended hose lengths or during cold running conditions
- Use this mode for the best finish with any RAC® SwitchTip



SEE THE
XT DIFFERENCE

graco.com/UltraXT

Ultra 1095 XT
Standard Series

FEATURING

UNRIVALED PUMP DURABILITY & PERFORMANCE PATENTED

SPRAYS 3X MORE GALLONS THAN THE NEAREST COMPETITOR

- Endurance piston pumps are made using the highest grade materials to deliver the industry's longest life
- Proven proprietary V-MAX Blue™ packings individually supported on chrome piston rod to deliver reliability you can count on
- Included on all 490 XT-650 XT and Standard Series XT models

ENDURANCE VORTEX TECHNOLOGY ON ALL MODELS

- Delivers the longest pump life by automatically rotating piston rod to extend pump life
- Virtually eliminates side loading

MORE PAINT APPLIED PER PISTON STROKE

- Up to 80% longer piston stroke than competitive models — enhances flow and boosts performance
- Extended piston stroke design increases wear surface and improves hard part life

ELIMINATE DOWNTIME WITH PROCONNECT JOBSITE SERVICEABILITY



Loosen the Clamping Nut Open Door & Remove Pump Remove Hose & Suction Tube



Eliminate Downtime with ProConnect On-the-Job Pump Replacement — now included on ALL XT Models

MADE IN THE USA WITH GLOBAL COMPONENTS

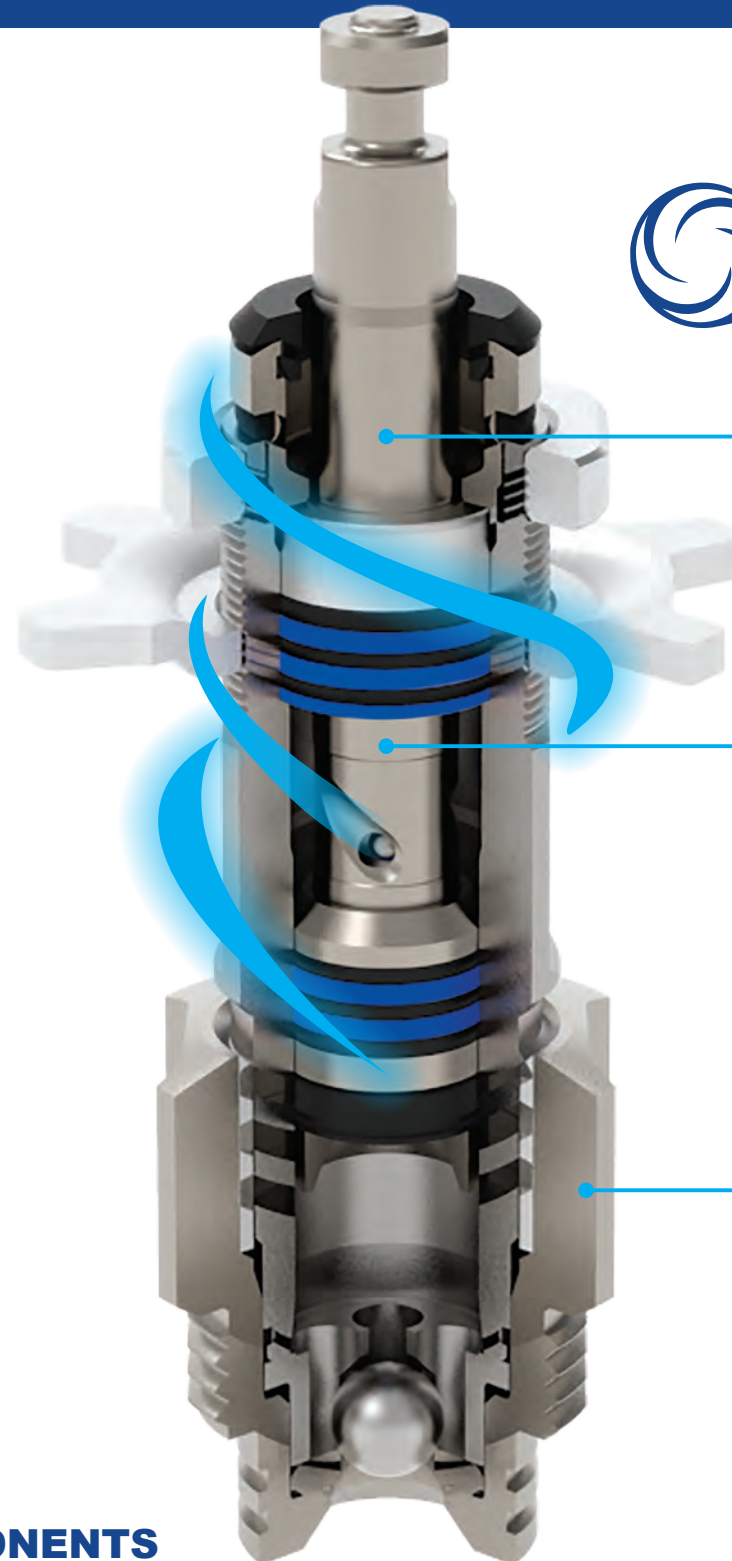

VORTEX TECHNOLOGY

Rotating rod for extended life

360° WEAR SURFACE

- Even loading delivers the longest pump life

HELICAL PISTON ROD DESIGN

- Delivers high-velocity flow to rotate pump rod as you spray
- The piston rod slowly turns — balancing wear and extending life

QUIKACCESS™ INTAKE

- Easy debris removal with knock-off foot valve
- Longer spray time with reversible inlet seat

PROCONTRACTOR **XT**

UPGRADE TO PROCONTRACTOR™ FOR 6X LONGER PUMP LIFE

- Proprietary piston and sleeve delivers 6X more litres pumped between repacks
- Included on all ProContractor Series models



Endurance Vortex MaxLife Pump
6X longer between repacks

Endurance Vortex MaxLife Extreme Pump
Extends pump rod life by 3X — delivering the industry's lowest cost of ownership

ULTRA XT MIDSIZE ELECTRIC SPRAYERS

490 XT | 495 XT | 650 XT

**INCREASED PERFORMANCE—
UNMATCHED RELIABILITY**

Midsized electric airless sprayers make it easier to get more work done in a day with increased flow and production rates.



Ultra 490 XT Stand

ULTRA XT STANDARD SERIES LARGE ELECTRIC SPRAYERS

1095 XT

**EVERYDAY RELIABILITY
FOR LARGER JOBS**

Larger painting jobs demand the proven quality and performance of Graco's Standard Series large electric sprayers to deliver a job well done, every time.



Ultra 1095 XT Standard Series

FEATURES FOUND ON ALL MIDSIZE & STANDARD XT SPRAYERS

NEW

SOUND OF QUALITY

Xtreme Torque Motor Technology

- Up to 10X Quieter
- Experience a new level of performance with the first motor ever designed specifically for airless spray

NEW

WORLD'S STEADIEST RUNNING PRESSURE

Rapid-Response Control with LED Digital Display

- Instantly adjusts motor speed to eliminate 75% of pressure fluctuations for a Perfect Airless Finish™
- Features a bright, easy-to-read LED display—see the performance from across the room!

NEW

PUSH BUTTON PERFORMANCE

Selectable Performance Modes

- Two Selectable Performance Modes offer unique performance levels to easily boost efficiency on every job
- Expand capability and range of applications with a single sprayer—like having two sprayers in one!

NEW

LONGEST LIFE BEFORE SERVICE

Endurance™ Vortex® Pump

- 3X Longer life than the closest competitor
- Automatically rotates rod while pumping delivering longest life

NEW

FASTEST SERVICE ON THE JOB

ProConnect Replacement System

- Fast and easy on-the-job replacement system
- One part solution to keep spraying

NEW

MAXIMISE UPTIME

TurboClean™ Cleaning System & WatchDog™ Pump Protection

- TurboClean delivers high-velocity fluid flow to clean the pump 3X faster using ½ the fluid
- WatchDog prevents pump damage if the material supply is too low by automatically shutting off the pump

EASY MAINTENANCE AND LESS CLOGGING

Easy Out™ Pump Filter

- Large inside-out filtering process ensures a quality finish

NEW INCREASED PERFORMANCE

MIDSIZE ELECTRIC	MAX TIP SIZE	MAX LPM	STAND	HI-BOY	LO-BOY
Ultra 490 XT	.025"	2.6	19D531	—	—
Ultra 495 XT	.027"	3.0	19D532	19D533	19D534
Ultra 650 XT	.029"	3.4	—	20B328	20B327

READY TO SPRAY WITH:

Contractor PC™ Gun
RAC X LP517 SwitchTip™ and Guard
BlueMax™ II 6.4mmx15m (1/4 x 50 ft) Airless Hose

NEW INCREASED PERFORMANCE

STANDARD LARGE ELECTRICS	MAX TIP SIZE	MAX LPM	HI-BOY
Ultra 695 XT Standard	.031"	4.0	19F712
Ultra 795 XT Standard	.033"	4.5	19F715
Ultra 1095 XT Standard	.035"	4.9	19F720

READY TO SPRAY WITH:

Contractor PC Gun
RAC X LP517 SwitchTip and Guard
BlueMax II 6.4mmx15m (1/4 x 50 ft) Airless Hose



ULTRA XT

PROCONTRACTOR SERIES

LARGE ELECTRIC SPRAYERS

INCLUDES ALL STANDARD SERIES FEATURES

PLUS:



Ultra 1095 XT
ProContractor Series

NEW SUPERIOR PUMP LIFE

Endurance Vortex MaxLife and MaxLife Extreme Piston Pumps

- Innovative MaxLife Technology last 6x longer between repacks —included on Ultra 695 XT and 795 XT ProContractor models
- MaxLife Extreme Technology extends rod life 3X longer delivering the industry's lower cost of ownership — included on Ultra 1095 XT ProContractor model

NEW EASY HOSE MANAGEMENT

QuikReel™ Hose Management System

- Deploy and rewind up to 90m (300 feet) of hose in seconds without twisting, kinking or coiling
- Use only the hose you need — the rest stays on the reel

NEW BREAKTHROUGH PRODUCTIVITY AND FINISH QUALITY WITH LED SMARTDISPLAY XT™ CONTRACTOR POWERSHOT XT™ CONNECTION READY

- Ready to Connect to the Contractor PowerShot XT out of the box — PowerShot gun sold separately
- Achieve the best finish in the industry by remotely controlling pressure from the gun and eliminating pressure surge with SmartStall™

NEW BLUELINK™ JOBSITE MANAGEMENT SYSTEM



- Know your job's progress, locate your sprayers and maximise uptime with this innovative technology that is free to use

NEW NEVER HAVE A FLAT AGAIN!

Flat Proof Tires

- Tires can't be punctured by nails, screws or other sharp debris

DURABLE FILTRATION

Crushproof Inlet Strainer

- Stands up to harsh impacts to maintain flow through filter

ACCESSORIES

Maximize your performance and get to the next job faster by customizing your sprayer with proven Graco accessories.

XT ACCESSORIES:

Upgrade your sprayer to maximize your productivity!

PART #	DESCRIPTION
25V145	Modular QuikReel Kit for 695 XT, 795 XT & 1095 XT
20B529	XT Airless Hopper Kit for 490 XT & 495 XT
20B198	Flat Proof Tires for 695 XT & 795 XT - order 2
17E687	Flat Proof Tires for 1095 XT - order 2
15V573	Crushproof Inlet Strainer for 695 XT, 795 XT & 1095 XT
18H310	Contractor PowerShot Gun
18H311	Contractor PowerShot XT Gun for all XT models
20B432	SmartDisplay XT • Connect Contractor PowerShot XT to any XT Sprayer to unlock a new level of performance for all XT models • Upgrade any XT Sprayer with BlueLink job-site management system



MAXIMIZE PERFORMANCE WITH THE CONTRACTOR POWERSHOT XT

REMOTELY ADJUSTS PRESSURE AT THE GUN TO UNLOCK A NEW LEVEL OF PERFORMANCE

- Electrically connects gun-to-sprayer, eliminating material blast on each trigger pull
- Instant Response Trigger virtually eliminates spits



Contractor PowerShot XT

NEW INCREASED PERFORMANCE

PROCONTRACTOR LARGE ELECTRICS	MAX TIP SIZE	MAX LPM	PART #	PISTON PUMP TECHNOLOGY
Ultra 695 XT ProContractor	.031"	4.0	19F714	Endurance Vortex MaxLife
Ultra 795 XT ProContractor	.033"	4.5	19F717	Endurance Vortex MaxLife
Ultra 1095 XT ProContractor	.035"	4.9	19F721	Endurance Vortex MaxLife Extreme

READY TO SPRAY WITH:

- Contractor PC Gun
- RAC X LP517 SwitchTip and Guard
- BlueMax II 6.4mmx15m (1/4 x 50 ft) Airless Hose

LEARN MORE ABOUT
CONTRACTOR POWERSHOT GUNS
graco.com/PowerShot



MADE IN THE USA WITH
GLOBAL COMPONENTS

INTRODUCING THE ULTRA XT LINEUP

SEE THE XT DIFFERENCE
graco.com/UltraXT



	Ultra 490 <i>XT</i>	Ultra 495 <i>XT</i>	Ultra 650 <i>XT</i>	Ultra 695 <i>XT</i>	Ultra 795 <i>XT</i>	Ultra 1095 <i>XT</i>
MAXIMUM TIP SIZE	INCREASED TIP SUPPORT 0.025" Max Tip	INCREASED TIP SUPPORT 0.027" Max Tip	0.029" Max Tip	0.031" Max Tip	0.033" Max Tip	INCREASED TIP SUPPORT 0.035" Max Tip
MAXIMUM PSI (BAR)	3,300 (227)	3,300 (227)	3,300 (227)	3,300 (227)	3,300 (227)	3,300 (227)
MAXIMUM LPM (GPM)	INCREASED FLOW 2.6 (0.70)	INCREASED FLOW 3.0 (0.80)	INCREASED FLOW 3.4 (0.90)	INCREASED FLOW 4.0 (1.05)	INCREASED FLOW 4.5 (1.20)	INCREASED FLOW 4.9 (1.30)
XTREME TORQUE MOTOR (HP)	✓ (1.3)	✓ (1.7)	✓ (1.9)	✓ (2.1)	✓ (2.3)	✓ (2.7)
WEIGHT KG (LB)	14 (31) Stand	14 (31) Stand	31 (69) Hi-Boy	42 (93) Standard	43 (94) Standard	51 (112) Standard
GUN SUPPORT: 1 GUNS 2 GUNS 3 GUNS	0.025" — —	0.027" — —	0.029" 0.019"	0.031" 0.023"	0.033" 0.025" 0.019"	0.035" 0.029" 0.023"



SERIES TYPE		MIDSIZE			STANDARD	PROCONTRACTOR	STANDARD	PROCONTRACTOR	STANDARD	PROCONTRACTOR	
MODEL	Cart Design – Part Number	Stand – 19D531	Stand – 19D532 Lo-Boy – 19D534 Hi-Boy – 19D533	Lo-Boy – 20B327 Hi-Boy – 20B328	Hi-Boy – 19F712	Hi-Boy – 19F714	Hi-Boy – 19F715	Hi-Boy – 19F717	Hi-Boy – 19F720	Hi-Boy – 19F721	
	NEW PISTON PUMP	Endurance Vortex	Endurance Vortex	Endurance Vortex	Endurance Vortex	Endurance Vortex	Endurance Vortex	Endurance Vortex	Endurance Vortex	Endurance Vortex	
PUMP	NEW VORTEX PISTON ROD	Chromex	Chromex	Chromex	Chromex	MaxLife	Chromex	MaxLife	Chromex	MaxLife Extreme	
	SLEEVE	—	—	Hardened SST	Hardened SST	MaxLife	Hardened SST	MaxLife	Hardened SST	MaxLife	
	NEW PROCONNECT REPLACEMENT SYSTEM	✓	✓	✓	✓	✓	✓	✓	✓	✓	
FEATURES	NEW RAPID-RESPONSE PRESSURE CONTROL	✓	✓	✓	✓	✓	✓	✓	✓	✓	
	NEW SELECTABLE PERFORMANCE MODES	✓	✓	✓	✓	✓	✓	✓	✓	✓	
	NEW LED DISPLAY	✓	✓	✓	✓	✓	✓	✓	✓	✓	
	NEW TURBOCLEAN	✓	✓	✓	✓	✓	✓	✓	✓	✓	
	NEW WATCHDOG PUMP PROTECTION	✓	✓	✓	✓	✓	✓	✓	✓	✓	
	EASY OUT FILTER (60 MESH)	✓	✓	✓	✓	✓	✓	✓	✓	✓	
	NEW QUIKREEL HOSE REEL				Optional	✓	Optional	✓	Optional	✓	
	NEW SMARTDISPLAY XT	Optional	Optional	Optional	Optional	✓	Optional	✓	Optional	✓	
	FLAT PROOF TIRES				Optional	✓	Optional	✓	Optional	✓	
	CRUSHPROOF INLET STRAINER				Optional	✓	Optional	✓	Optional	✓	
	CONTRACTOR PC GUN	✓	✓	✓	✓	✓	✓	✓	✓	✓	
	SWITCHTIP	RAC X LP 517	RAC X LP 517	RAC X LP 517	RAC X LP 517	RAC X LP 517	RAC X LP 517	RAC X LP 517	RAC X LP 517	RAC X LP 517	
	HOSE	6.4 mm x 15 m (1/4 in x 50 ft) Blue Max II Airless	6.4 mm x 15 m (1/4 in x 50 ft) Blue Max II Airless	6.4 mm x 15 m (1/4 in x 50 ft) Blue Max II Airless	6.4 mm x 15 m (1/4 in x 50 ft) Blue Max II Airless	6.4 mm x 15 m (1/4 in x 50 ft) Blue Max II Airless	6.4 mm x 15 m (1/4 in x 50 ft) Blue Max II Airless	6.4 mm x 15 m (1/4 in x 50 ft) Blue Max II Airless	6.4 mm x 15 m (1/4 in x 50 ft) Blue Max II Airless	6.4 mm x 15 m (1/4 in x 50 ft) Blue Max II Airless	6.4 mm x 15 m (1/4 in x 50 ft) Blue Max II Airless
	WEAR PARTS	REPLACEMENT PUMP	19D873	19D873	2002382	2001548 / 2001549*	2001549	2001573 / 2001574*	2001574	2001550 / 2001551*	2001551
REPAIR KIT		18B260	18B260	18B260	248212 / 17H838**	17H841**	248212 / 17H838**	17H841**	248213 / 17H839**	17K162 / 17H843**	

*Endurance Vortex MaxLife Pumps compatible with ALL XT Standard Sprayers (695 XT, 795 XT & 1095 XT)
**QuickPak Repair Kits — Repack your pump in minutes with modular pre-oiled cartridge packings.



ABOUT GRACO

PROVEN QUALITY. LEADING TECHNOLOGY.

Founded in 1926, Graco is a world leader in fluid handling systems and components. Graco products move, measure, control, dispense and apply a wide range of fluids and viscous materials used in vehicle lubrication, commercial and industrial settings.

The company's success is based on its unwavering commitment to technical excellence, world-class manufacturing and unparalleled customer service. Working closely with qualified distributors, Graco offers systems, products and technology that set the quality standard in a wide range of fluid handling solutions. Graco provides equipment for spray finishing, protective coating, paint circulation, lubrication, and dispensing sealants and adhesives, along with power application equipment for the contractor industry. Graco's ongoing investment in fluid management and control will continue to provide innovative solutions to a diverse global market.

GRACO LOCATIONS

MAILING ADDRESS

P.O. Box 1441
Minneapolis, MN 55440-1441
Tel: +612-623-6000
Fax: +612-623-6777

AMERICAS

MINNESOTA
Worldwide Headquarters
Graco Inc.
88-11th Avenue N.E.
Minneapolis, MN 55413

EUROPE

BELGIUM
European Headquarters
Graco N.V.
Industrieterrein-Oude Bunders
Slakweidestraat 31
3630 Maasmechelen,
Belgium
Tel: +32 89 770 700
Fax: +32 89 770 777

ASIA PACIFIC

AUSTRALIA
Graco Australia Pty Ltd.
Suite 17, 2 Enterprise Drive
Bundoora, Victoria 3083
Australia
Tel: +61 3 9468 8500
Fax: +61 3 9468 8599

CHINA (AP Headquarters)
Graco Fluid Equipment
(Shanghai) Co., Ltd
Building 7, NO. 1 - 2, Wenshui
Road 299
Jing'an District, Shanghai
200436, P.R.China
Tel: +86 512 6260 5711
Fax: +86 21 6495 0077

INDIA

Graco India Pvt Ltd
Plot No 295, Udyog Vihar Phase-IV
Gurugram - 122015 (Haryana)
India
Phone: +91 124 661 0200
Fax: +91 124 661 0201

JAPAN

Graco K.K.
1-27-12 Hayabuchi
Tsuzuki-ku
Yokohama City, Japan 2240025
Tel: +81 45 593 7300
Fax: +81 45 593 7301

KOREA

Graco Korea Inc.
38, Samsung 1-ro 1-gil,
Hwaseong-si, Gyeonggi-do.
18449
Republic of Korea
Tel : +82 31 8015 0961
Fax : +82 31 613 9801

SALES/ DISTRIBUTION/ SERVICE

Call today for product information or to request a demonstration.

CHINA/SOUTH EAST ASIA: + 86 512 62605711

INDIA: +91 124 6610200

AUSTRALIA and NEW ZEALAND: +61 3 9468 8500

Or visit us at www.graco.com



EVERY GRACO PRODUCTS COMES WITH A+ CUSTOMER SERVICE.

3-YEAR WARRANTY*

Coverage against defects in materials and workmanship on the entire striper.